



**CONFIDENTIAL**

THIS DOCUMENT AND INFORMATION CONTAINED HEREIN IS PROPRIETARY AND CONFIDENTIAL TO PRECOR STRENGTH INCORPORATED. RECIPIENTS OF THIS DOCUMENT AGREE THAT THIS DOCUMENT AND INFORMATION WILL NOT BE USED FOR ANY PURPOSE, REPRODUCED OR COPIED, OR DISCLOSED TO ANY THIRD PARTY, EITHER IN WHOLE OR IN PART WITHOUT PRIOR EXPRESS WRITTEN PERMISSION OF PRECOR STRENGTH, INCORPORATED.

**PRECOR** USA  
PRECOR STRENGTH, INC.

28936 AVE WILLIAMS  
VALENCIA, CA 91355  
TELEPHONE: 661-362-0300

SIGN IN BLUE OR BLACK INK ONLY		
DRWN BY	01.02.07	MGP
DWG CHK		
ENG	01.02.07	RSG
MPG ENG		
CS		
QA		
ID		
REG		

UNLESS OTHERWISE SPECIFIED:  
DIMENSIONS ARE IN INCHES  
TOLERANCES ARE:  
LIN .X=±0.1 .XXX=±0.010  
LIN .XX=±0.02 .XXXX=±0.0001  
ANGULAR: ±1.0°  
ALL DIMS AFTER PLATING  
BREAK ALL SHARP EDGES  
REMOVE ALL BURRS  
ALL ANGLES & BENDS 90°  
DWG PER ASME Y14.5M-1994  
DO NOT SCALE DRAWING  
ALL MACHINED SURFACES

PRODUCT: STRENGTH

ASSEMBLY CONNECTION, 10.5, W/ 1 PULLEY HSG

SIZE PAGE OF  
C 1 1

DWG. NO. SUBREV  
CW31868-402 A

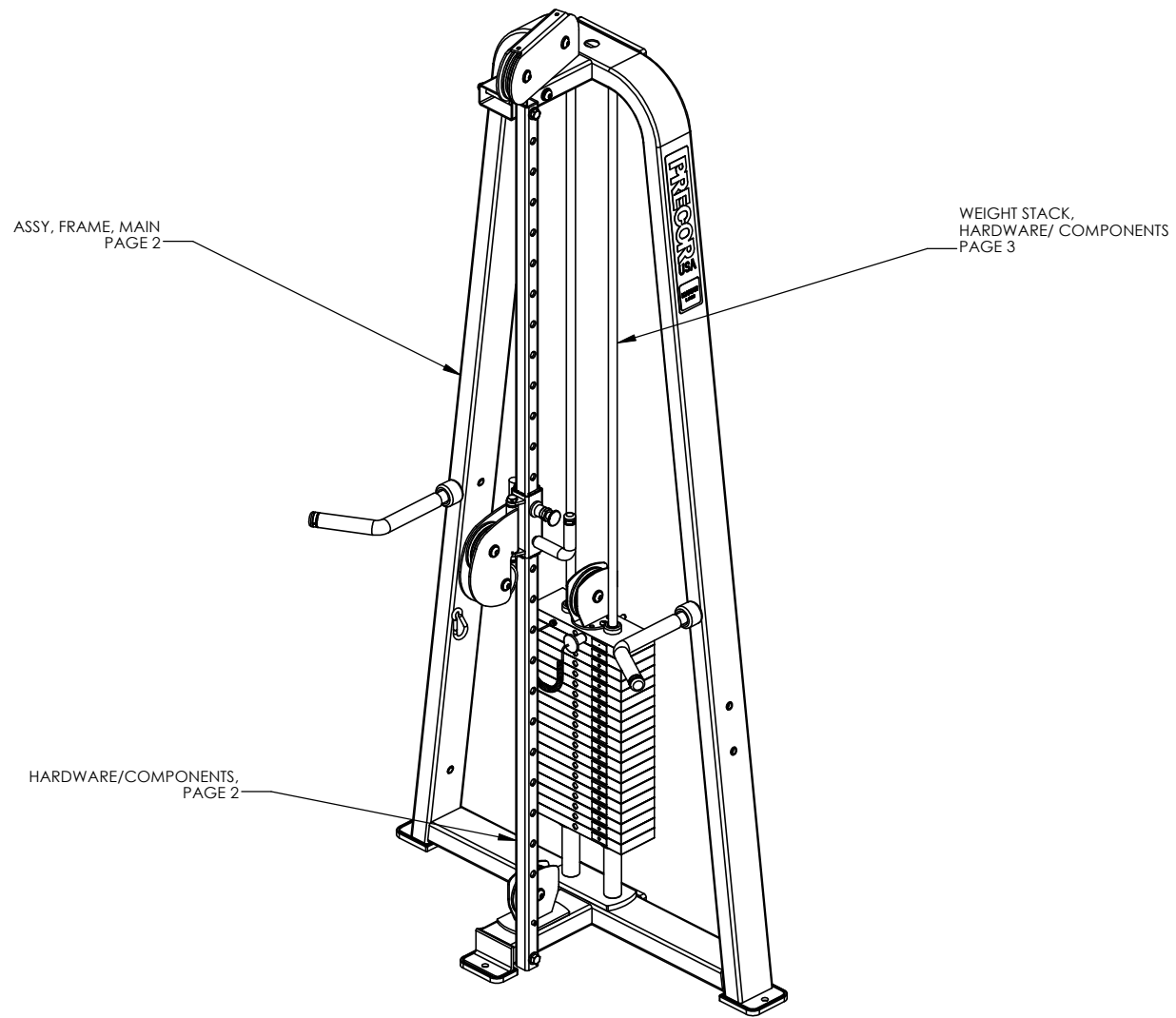

P/N: CW34920-401	SUBREV: A
DRAWN BY: VLE	DATE: 06.24.09
SHEET 1 OF 3	

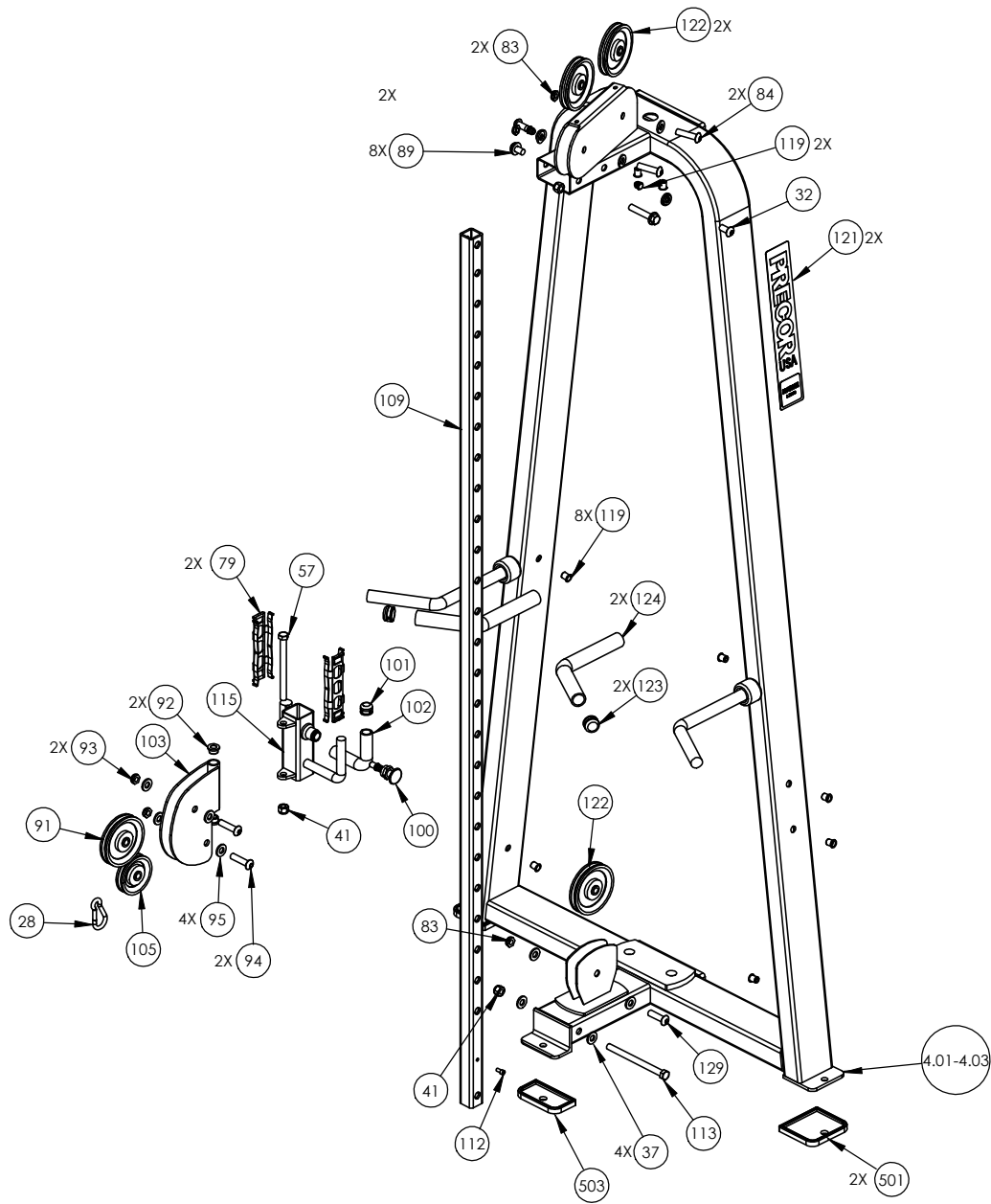

P/N: CW34920-401	SUBREV: A
DRAWN BY: VLE	DATE: 06.24.09
SHEET 2 OF 3	

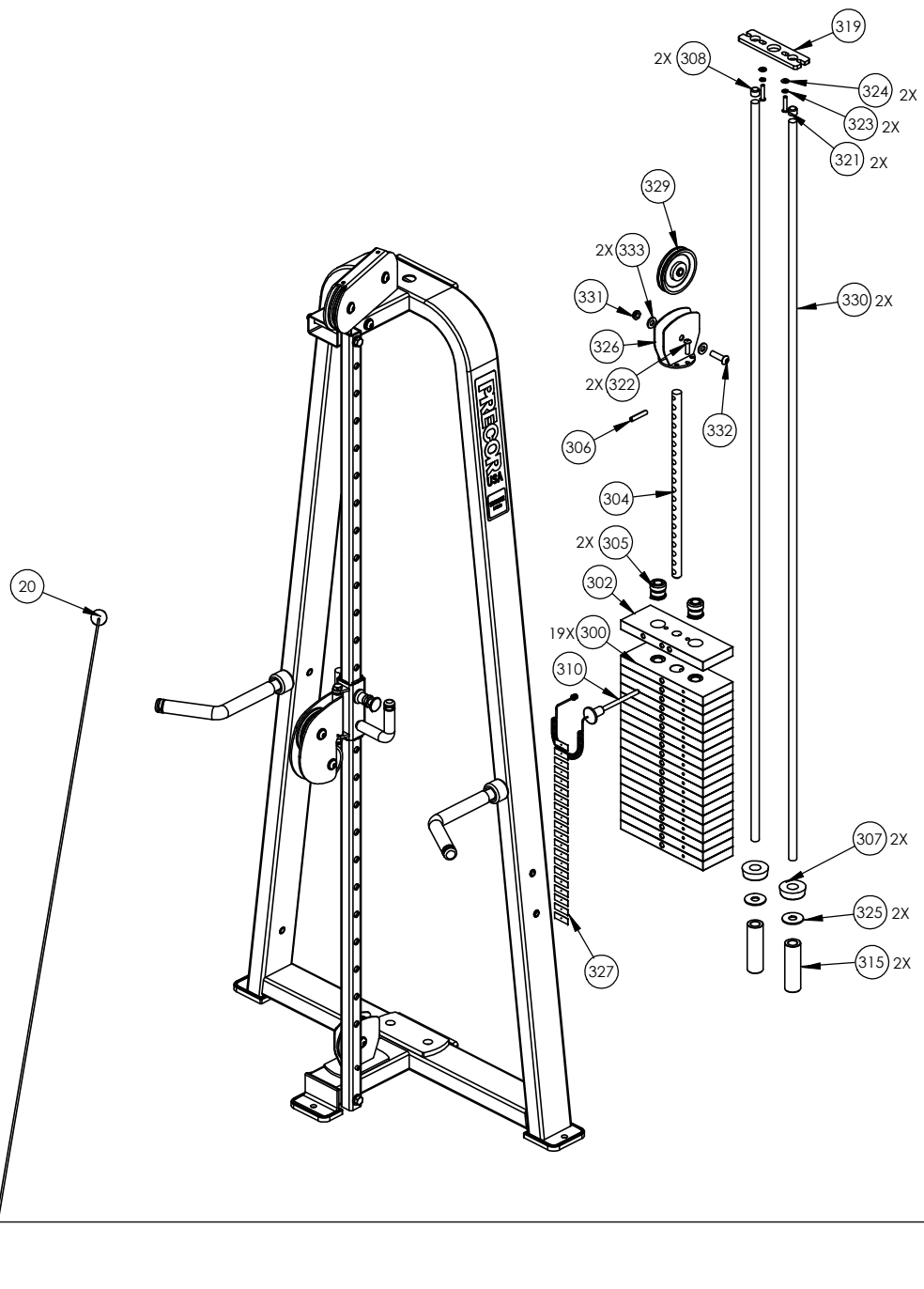

P/N: CW34920-401	SUBREV: A
DRAWN BY: VLE	DATE: 06.24.09
SHEET 3 OF 3	

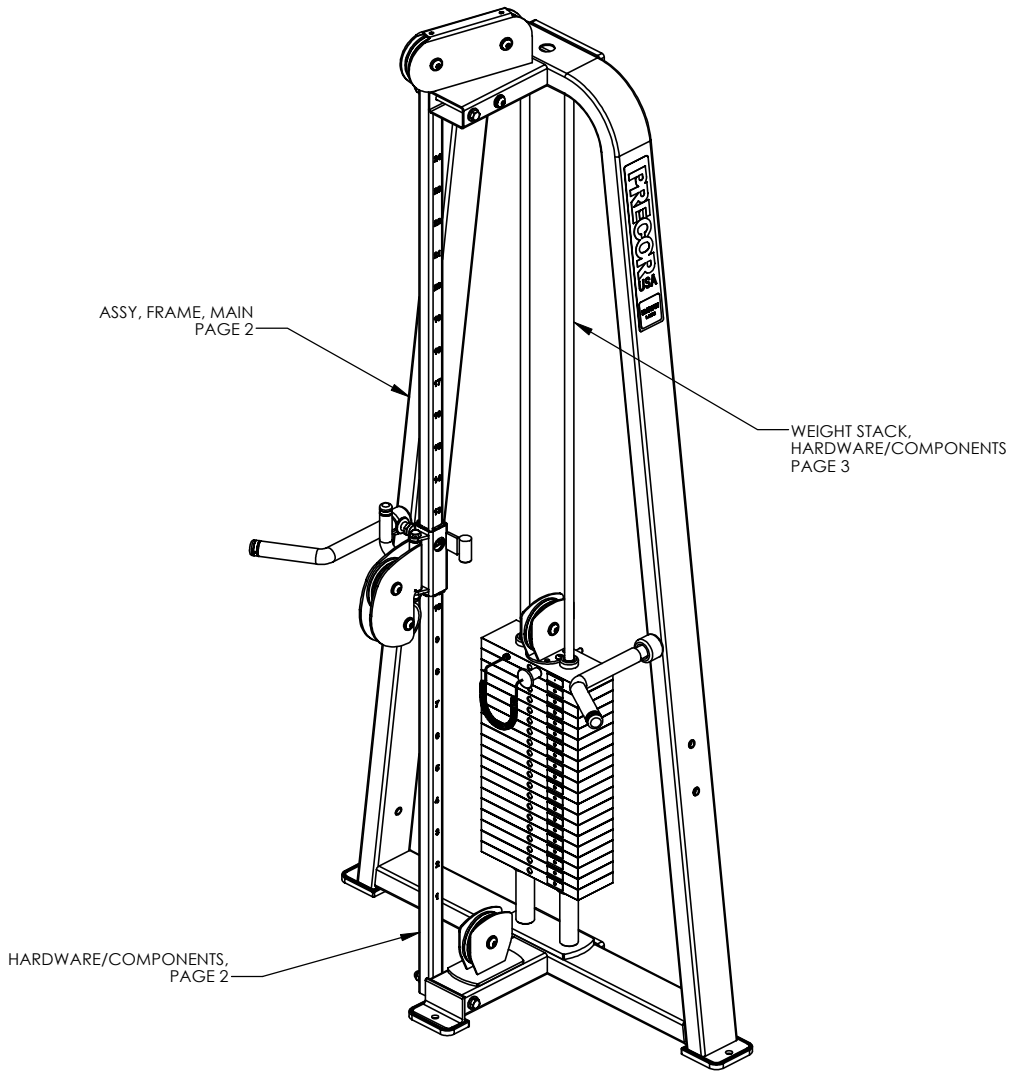

P/N: CW34921-401	SUBREV: A
DRAWN BY: VLE	DATE: 06.24.09
SHEET 1 OF 3	

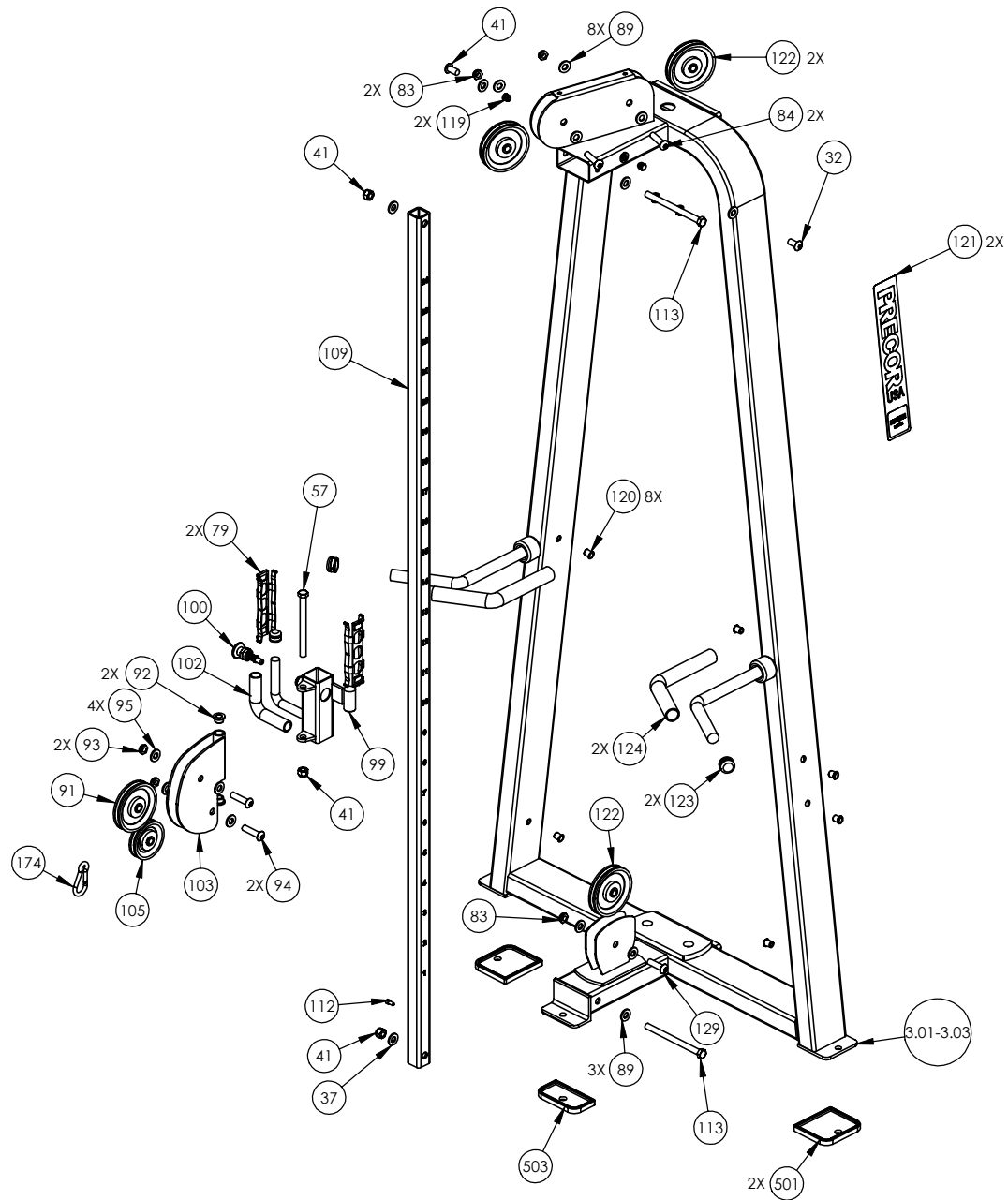

P/N: CW34921-401	SUBREV: A
DRAWN BY: VLE	DATE: 06.24.09
SHEET 2 OF 3	

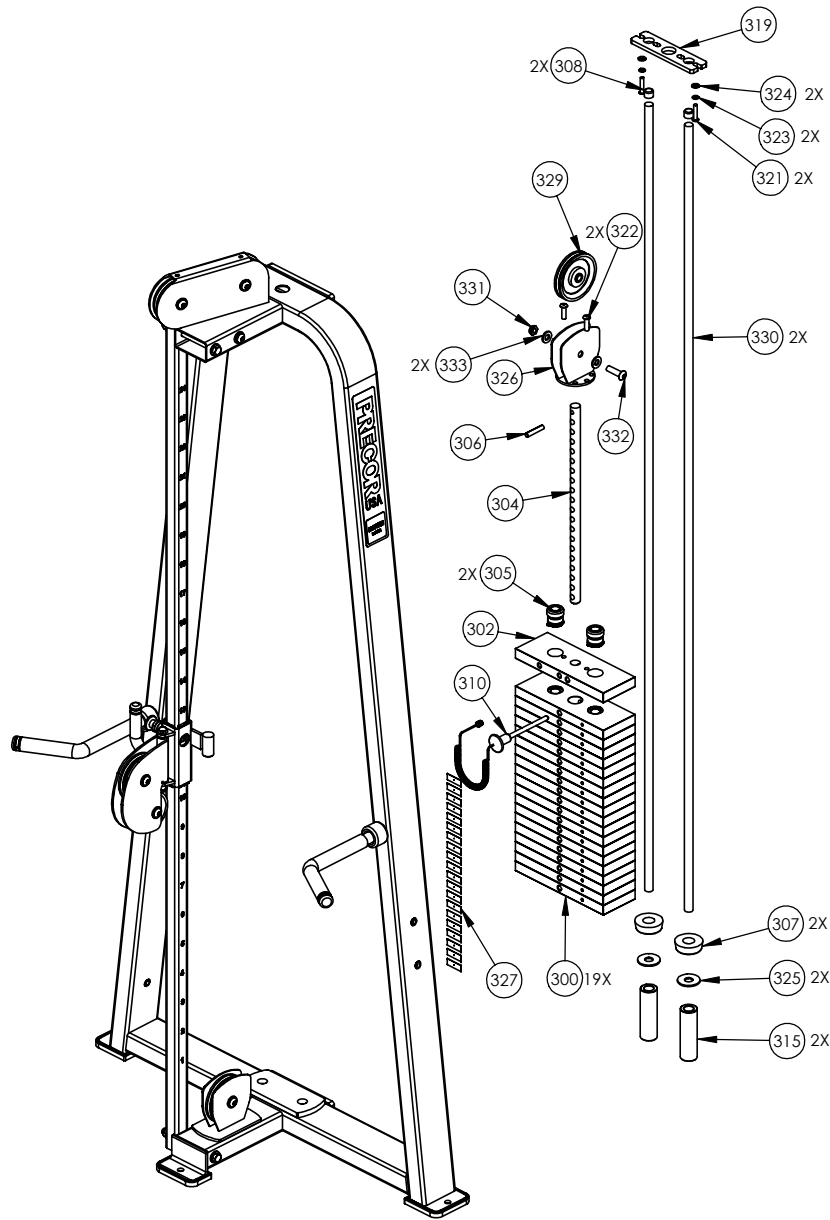

P/N: CW34921-401	SUBREV: A
DRAWN BY: VLE	DATE: 06.24.09
SHEET 3 OF 3	

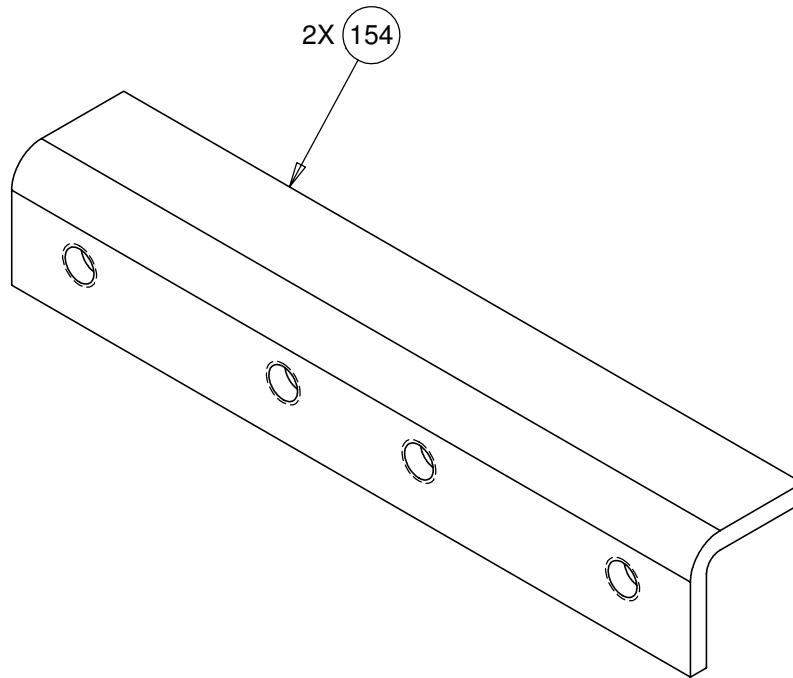

**CONFIDENTIAL**

THIS DOCUMENT AND INFORMATION CONTAINED HEREIN IS PROPRIETARY AND CONFIDENTIAL TO PRECOR STRENGTH INCORPORATED. RECIPIENTS OF THIS DOCUMENT AGREE THAT THIS DOCUMENT AND INFORMATION WILL NOT BE USED FOR ANY PURPOSE, REPRODUCED OR COPIED, OR DISCLOSED TO ANY THIRD PARTY, EITHER IN WHOLE OR IN PART WITHOUT PRIOR EXPRESS WRITTEN PERMISSION OF PRECOR STRENGTH INCORPORATED.

**PRECOR USA**  
PRECOR STRENGTH, INC.

**28936 AVE WILLIAMS  
VALENCIA, CA 91355  
TELEPHONE: 661-362-0300**

SIGN IN BLUE OR BLACK INK ONLY			UNLESS OTHERWISE SPECIFIED: DIMENSIONS ARE IN INCHES TOLERANCES ARE: LIN .X=±0.1 .XXX=±0.010 LIN .XX=±0.02 .XXXX=±0.0001 ANGULAR: ±1.0° ALL DIMS AFTER PLATING BREAK ALL SHARP EDGES REMOVE ALL BURRS ALL ANGLES & BENDS 90° DWG PER ASME Y14.5M-1994 DO NOT SCALE DRAWING <sup>125</sup> ALL MACHINED SURFACES		
DRWN BY	08.27.09	VLE			
DWG CHK					
ENG	08.27.09	VLE			
MFG ENG					
CS					
QA					
ID			SIZE	PAGE	OF
REG			A	1	1

PRODUCT:  
STRENGTH

STEEL, CHANNEL

DWG. NO. CW33293-402 SUBREV A



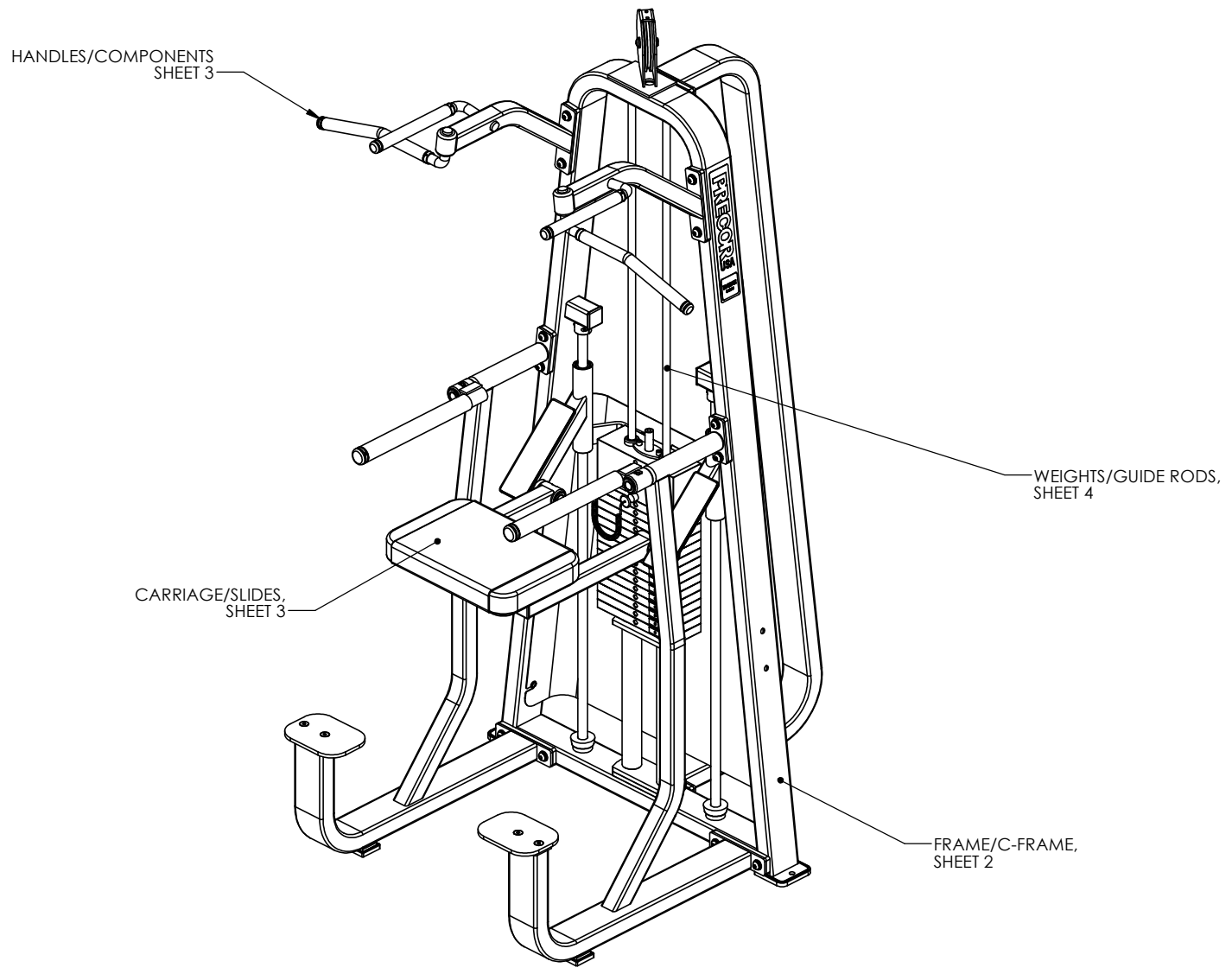

CW320KS	P/N: CW33596-101	SUBREV: C
DRAWN BY: JEC	DATE: 09.11.08	SHEET 1 OF 4

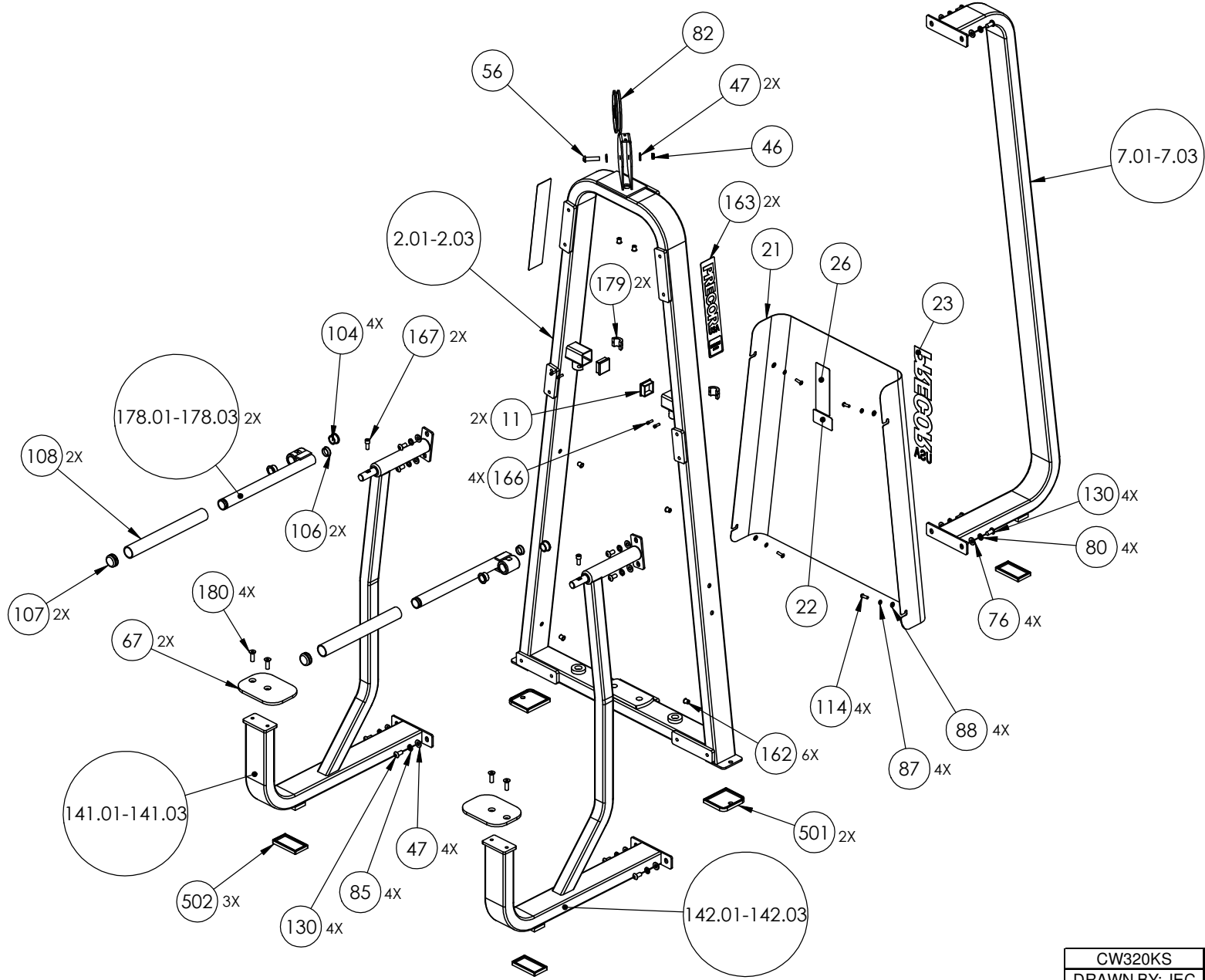

CW320KS	P/N: CW33596-101	SUBREV: C
DRAWN BY: JEC	DATE: 09.11.08	SHEET 2 OF 4

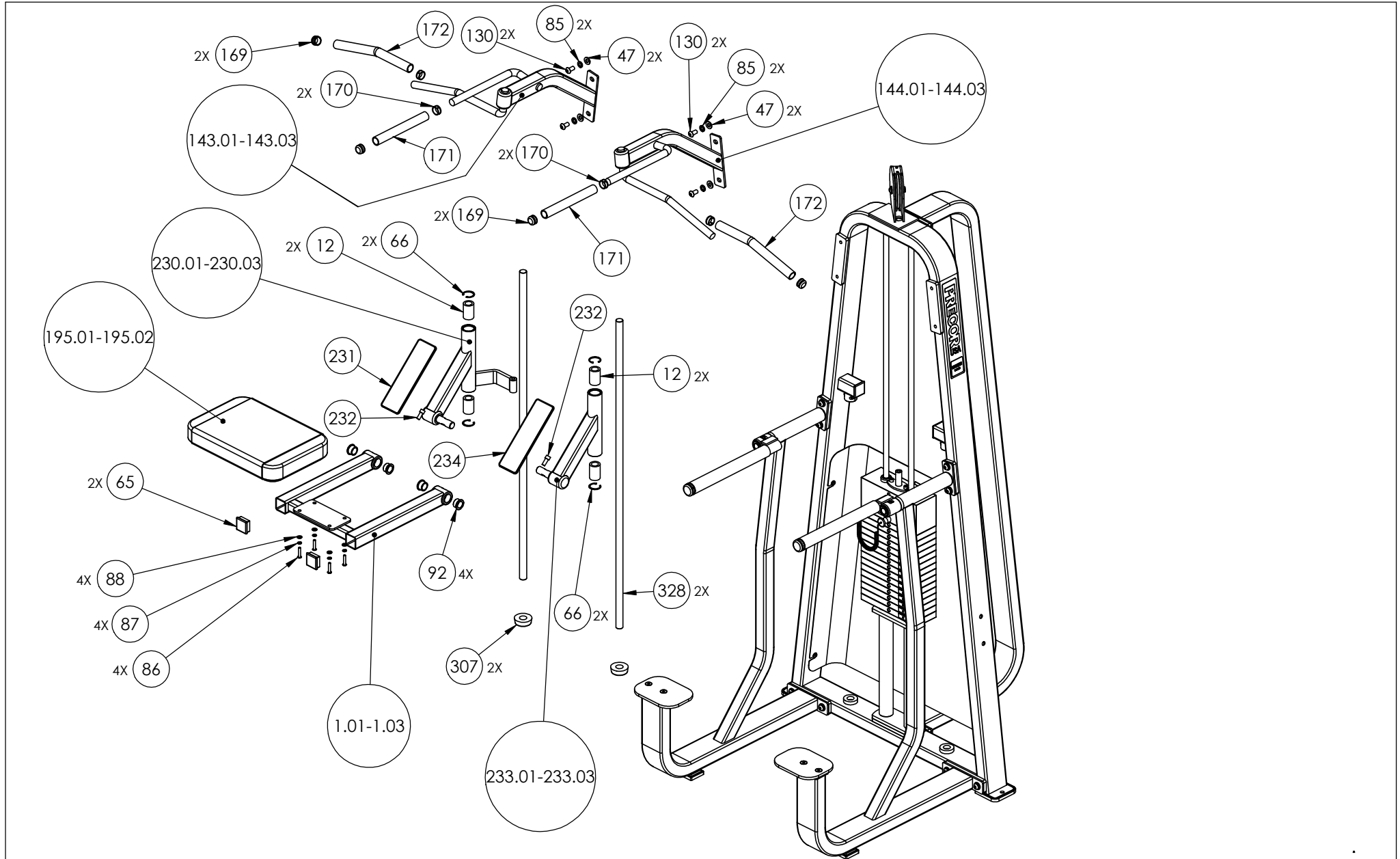

CW320KS	P/N: CW33596-101	SUBREV: C
DRAWN BY: JEC	DATE: 09.11.08	SHEET 3 OF 4

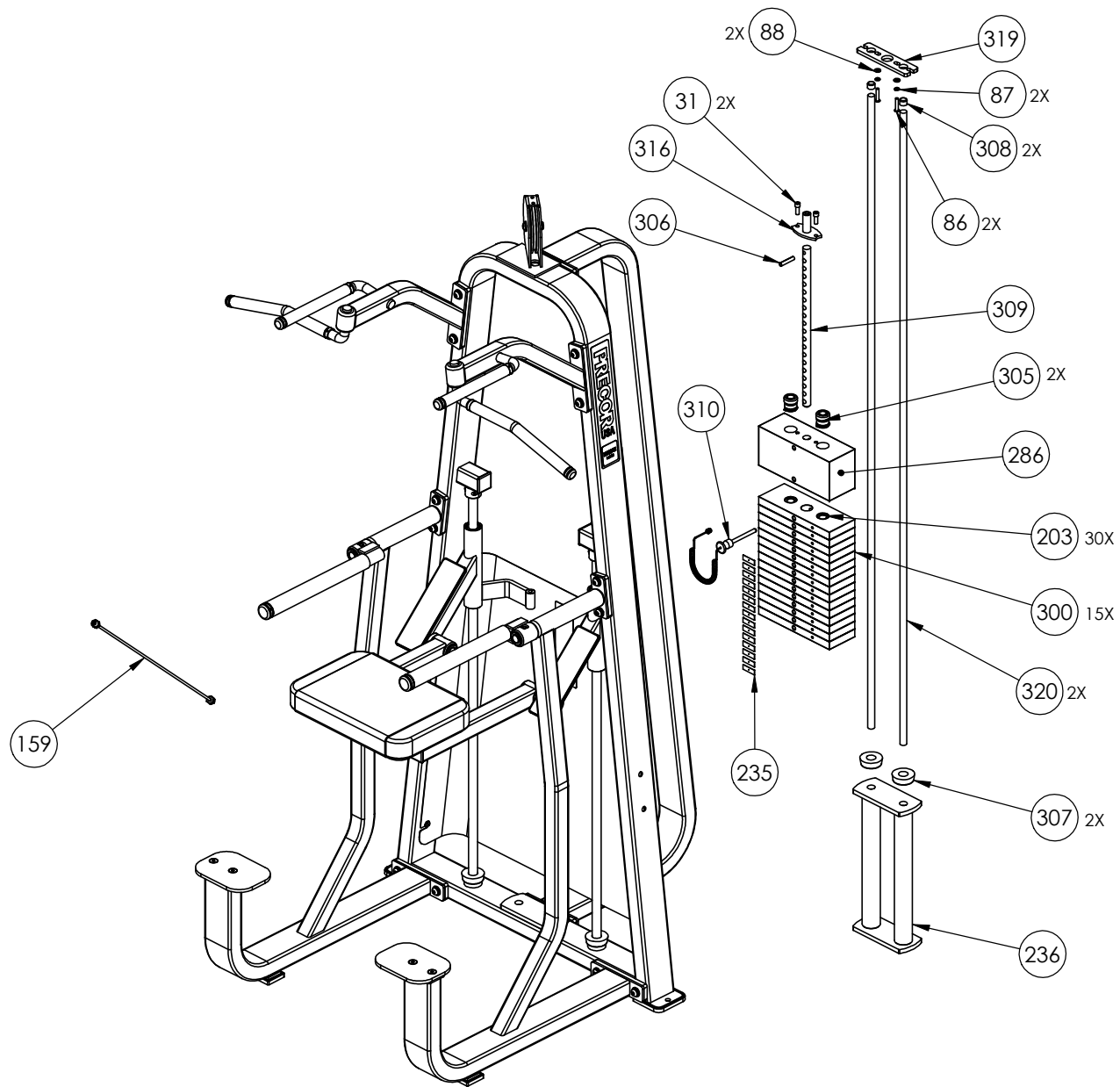

CW320KS	P/N: CW33596-101	SUBREV: C
DRAWN BY: JEC	DATE: 09.11.08	SHEET 4 OF 4

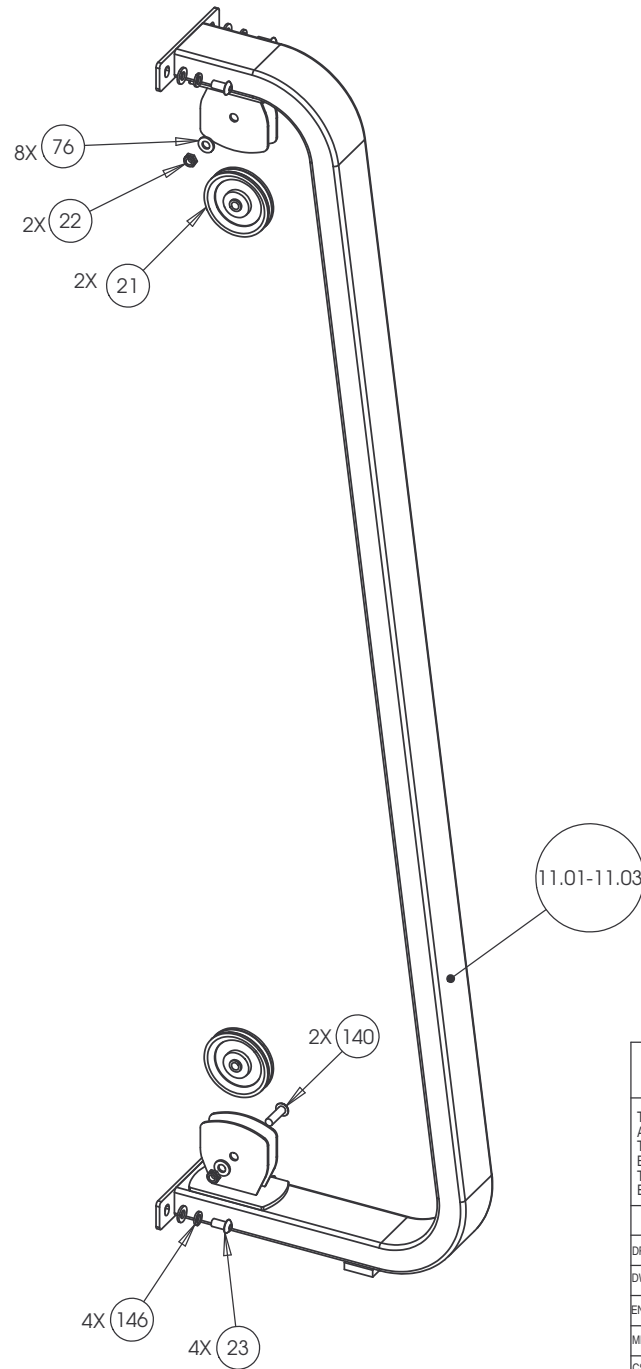

**CONFIDENTIAL**

THIS DOCUMENT AND INFORMATION CONTAINED HEREIN IS PROPRIETARY AND CONFIDENTIAL TO PRECOR STRENGTH INCORPORATED. RECIPIENTS OF THIS DOCUMENT AGREE THAT THIS DOCUMENT AND INFORMATION WILL NOT BE USED FOR ANY PURPOSE, REPRODUCED OR COPIED, OR DISCLOSED TO ANY THIRD PARTY, EITHER IN WHOLE OR IN PART WITHOUT PRIOR EXPRESS WRITTEN PERMISSION OF PRECOR STRENGTH, INCORPORATED.

**PRECOR** USA  
 PRECOR STRENGTH, INC.

28936 AVE WILLIAMS  
 VALENCIA, CA 91355  
 TELEPHONE: 661-362-0300

SIGN IN BLUE OR BLACK INK ONLY			UNLESS OTHERWISE SPECIFIED: DIMENSIONS ARE IN INCHES		
DRWN BY	01.02.07	MGP	TOLERANCES ARE:		
DWG CHK			LIN	.X=±0.1	.XXX=±0.010
ENG	01.02.07	RSG	LIN	.XX=±0.02	.XXXX=±0.0001
MFG ENG			ANGULAR: ±1.0°		
CS			ALL DIMS AFTER PLATING		
QA			BREAK ALL SHARP EDGES		
ID			REMOVE ALL BURRS		
REG			ALL ANGLES & BENDS 90°		
			DWG PER ASME Y14.5M-1994		
			DO NOT SCALE DRAWING		
			ALL MACHINED SURFACES		
			SIZE	PAGE	OF
			C	1	1

PRODUCT:	STRENGTH
ASSEMBLY FLANGED "C" FRAME, W- DOUBLE PULLEY HSG	
DWG. NO.	CW33212-401
SUBREV	A

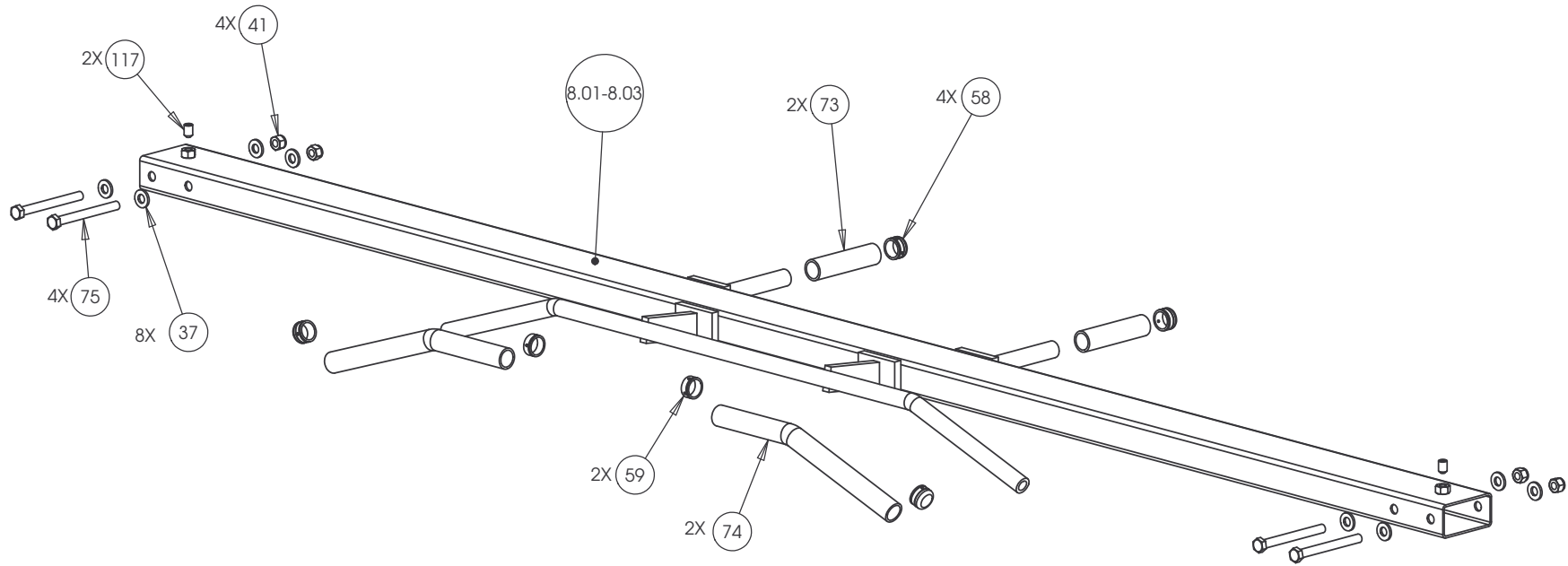

**CONFIDENTIAL**

THIS DOCUMENT AND INFORMATION CONTAINED HEREIN IS PROPRIETARY AND CONFIDENTIAL TO PRECOR STRENGTH INCORPORATED. RECIPIENTS OF THIS DOCUMENT AGREE THAT THIS DOCUMENT AND INFORMATION WILL NOT BE USED FOR ANY PURPOSE, REPRODUCED OR COPIED, OR DISCLOSED TO ANY THIRD PARTY, EITHER IN WHOLE OR IN PART WITHOUT PRIOR EXPRESS WRITTEN PERMISSION OF PRECOR STRENGTH, INCORPORATED.

**PRECOR** USA  
PRECOR STRENGTH, INC.

28936 AVE WILLIAMS  
VALENCIA, CA 91355  
TELEPHONE: 661-362-0300

SIGN IN BLUE OR BLACK INK ONLY		UNLESS OTHERWISE SPECIFIED: DIMENSIONS ARE IN INCHES TOLERANCES ARE: LIN .X=±0.1 .XXX=±0.010 LIN .XX=±0.02 .XXXX=±0.0001 ANGULAR: ±1.0° ALL DIMS AFTER PLATING BREAK ALL SHARP EDGES REMOVE ALL BURRS ALL ANGLES & BENDS 90° DWG PER ASME Y14.5M-1994 DO NOT SCALE DRAWING ALL MACHINED SURFACES	
DRWN BY	01.02.07	MGP	
DWG CHK			
ENG	01.02.07	RSG	
MFG ENG			
CS			
QA			
ID			
REG			

PRODUCT: <b>STRENGTH</b>	
<b>ASSEMBLY CONNECTION, 107 IN, CROSSBEAM W-HANDLES</b>	
DWG. NO. <b>CW31878-401</b>	SUBREV <b>A</b>